



Solutions for special
applications

PSI Steel Roller Rings, Steel Insulators and Steel Pipe Supports



Pipeline Accessories

By the laying of casing pipes there are applications with extreme requirements where the plastic insulators can be used no more.

Examples:

- multiple pipes in exact defined position
- long distances
- permanent pipe-movement
- high temperature
- heavy weight
- integrated tensile
- hanging construction
- rollers for e.g. rough casing pipe surfaces

Call us for customised solutions.

Example:

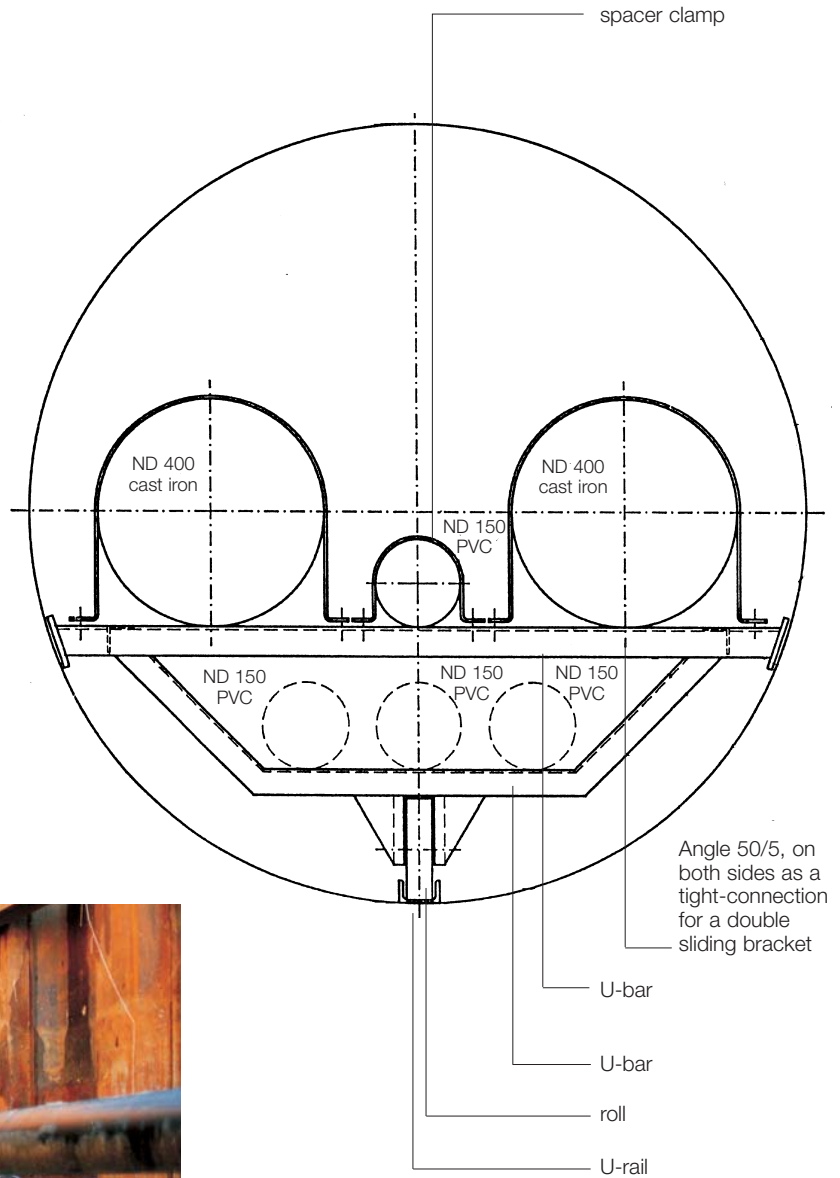

PSI Steel Roller Rings and Steel Insulators

General Information

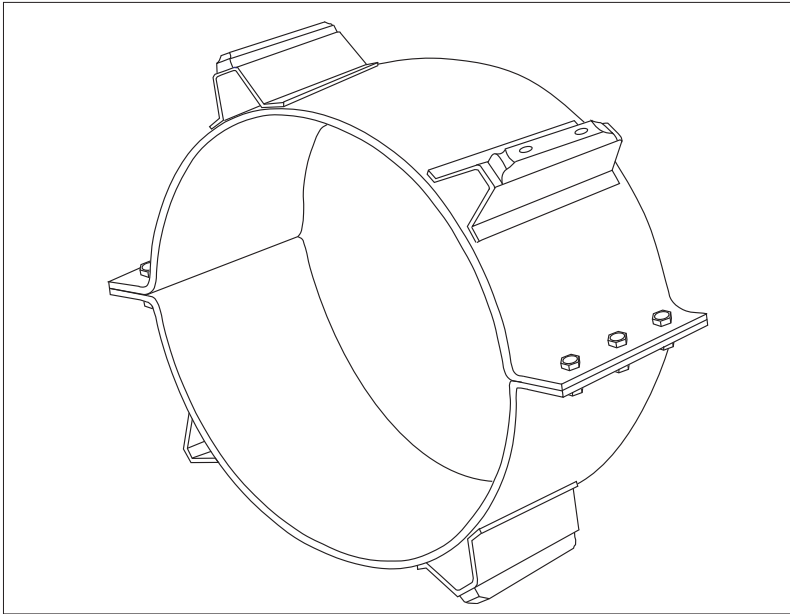

Often it is not possible to lay pipes in open ditches. For example, for rail or road crossings it is first necessary to drive casings underground. By using PSI steel insulators or roller rings, the carrier pipe can be inserted into the casing sleeve safely and efficient.

Skid roller insulators or steel insulators

- facilitate introduction by reducing friction between the carrier pipe and the casing, support the carrier pipe,
- act as spacers between pipe and casing; pipes can thus be placed in concentric or eccentric positions, ensure electric insulation of both pipes since the skid material is plastic if required.

Steel insulators and steel roller rings

Steel insulators constructions are preferred over plastic insulators in the following cases:

- high medium temperatures
- strong pressure in large diameters (load-bearing capacity)
- wide gap between casing and carrier pipe diameter (up to 600 mm)
- long distances
- rough carrier pipe surface

Typical steel insulator assembly

Each ring consists of two semi-circular halves which are clamped together by hexagonal bolts and nuts. Segments tailored to suit customer requirements.

Note

Performance data and technical information provided herein is intended for guide line purposes only. Suitability of product configurations for specific applications should be determined by the user.

PSI Steel Roller Rings and Steel Insulators

Technical Data



Material

Ring halves and skid struts are made of steel. Surfaces without corrosion protection (black), or bitumen coated, plastic coated, as required, hot-galvanized resp. in stainless steel.

Runners made of plastic, steel or stainless steel.

Sliding corpus made of strong polyethylen or steel.

Screws of high-resistance galvanized steel or stainless steel if required.

Varying skid heights on both the upper and the lower halves permit any position of the carrier pipe in the casing.

At longer distances with guiding rail if required.

Combination examples

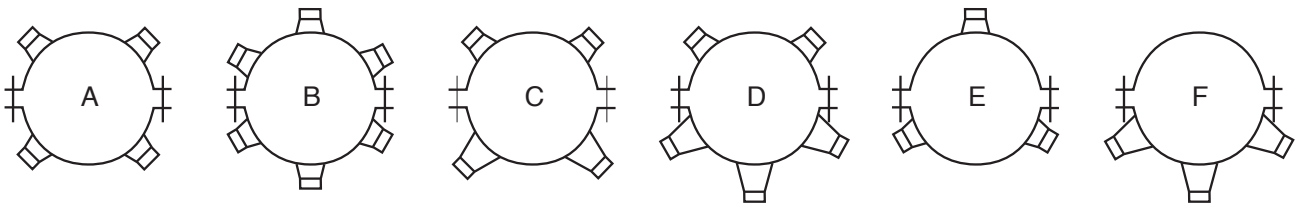

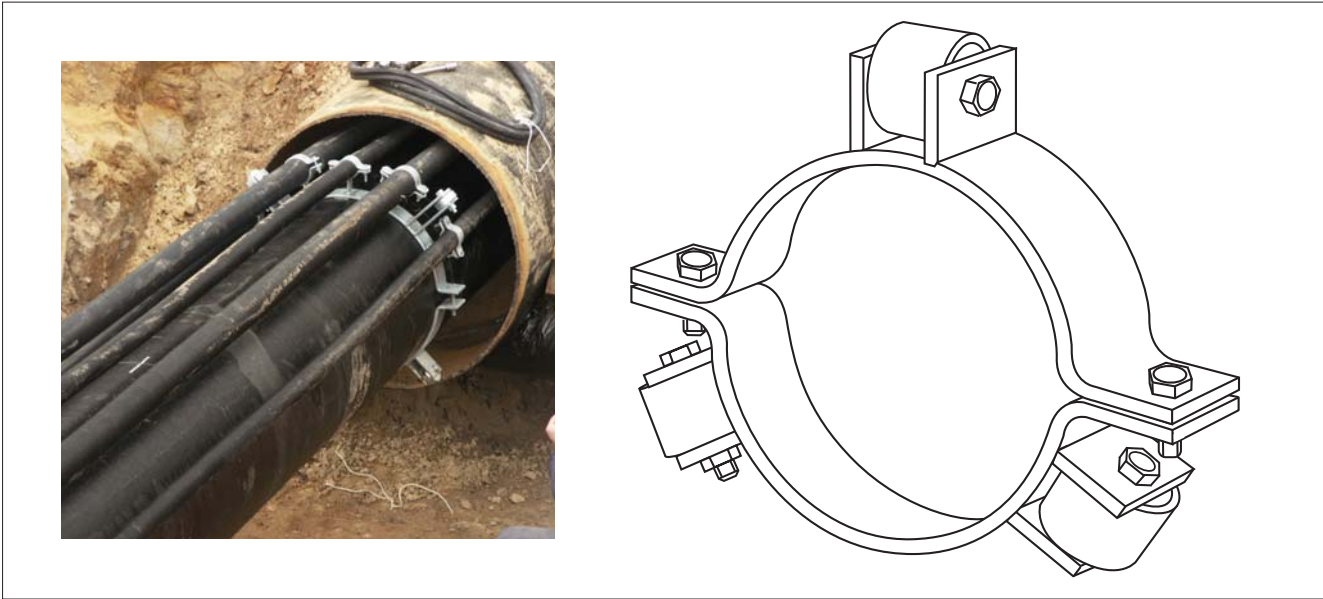

Steel roller rings for one or multiple medium pipes

The ring consists of two halves which are held together by screws. Between the welded skirts, rolls are bedded which have the same Purpose as the sliding corpus of the insulator rings.

Roller ring with clamping ring for positive sleeve connection

To ensure that socket joints remain tight, we can offer a tie bar system which consists of a roller ring fixed on one side of the socket and a clamping ring on the other side. The two are joint by the tie bars.

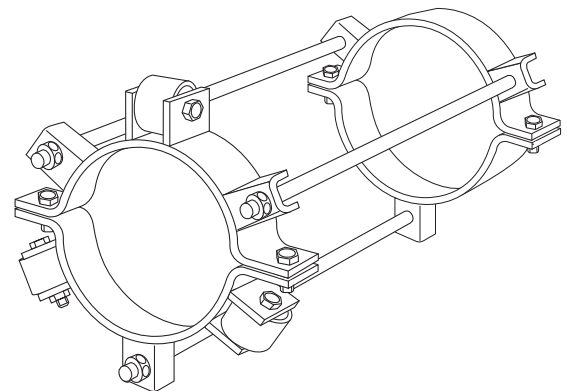
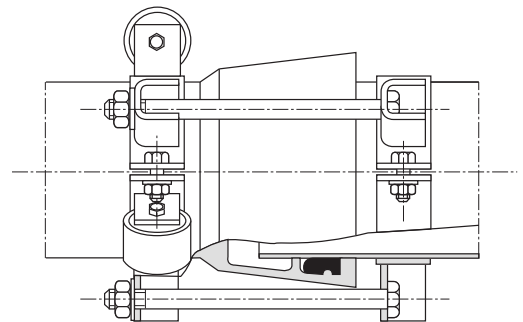

Multiple clamping

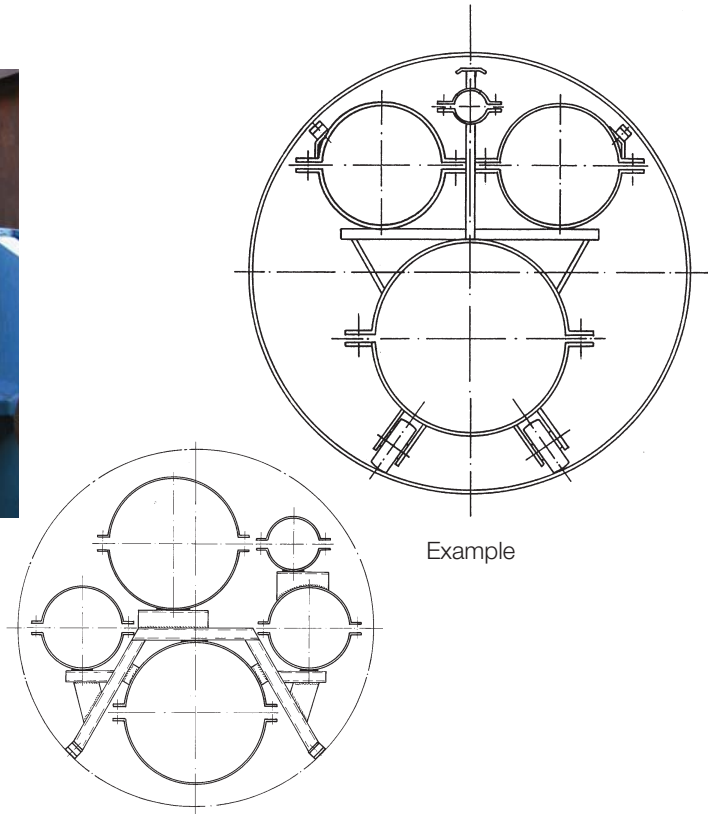

PSI steel constructions as required by the customer.

All types are tailor-made.

Suitable carrier pipe diameters are between 20 and 1200 mm.

We will be pleased to assist you in selecting a suitable type.

- Carrier pipe O.D.
- Sleeve O.D.
- Weight I.D.
- Casing I.D.
- Drawing of carrier pipe position
- Type of medium
- Type of connection of carrier pipe segments
- Length of casing runs
- Buoyancy safety favored
- Torsional security.

Price on request.

Delivery time approx. 3 weeks, depending on quantity and sizes ordered.

Performance data and technical information provided herein is intended for guide line purposes only. Suitability of product configuration for specific applications should be determined by the user.

Technical changes reserved or request.

PSI application form for steel roller rings/steel insulators.

PSI Steel Pipe Support

Rigid and adjustable version



Material: steel, zinc-plated steel, stainless steel (V2A, V4A, etc.)

For pipe dimensions up to ND3000.

On request with verifiable load calculations.

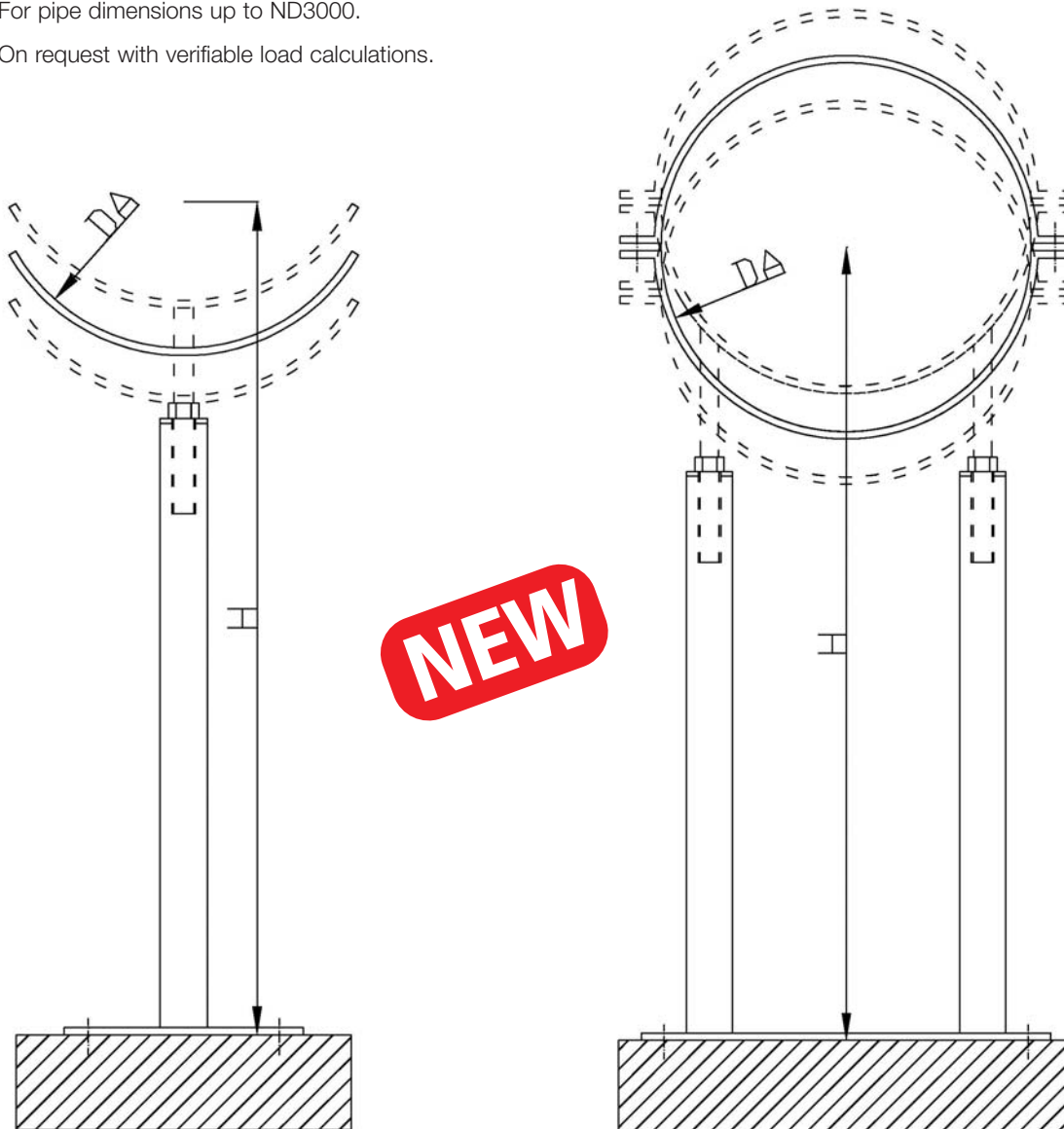

Offer on request. Production according to customer's specification.