

General Information

Sectional View

Technical Data



PSI Kompakt and Wall Sleeve with Fixed / Loose Flange



Pipeline Accessories

PSI Kompakt Seals and Wall Sleeves with Fixed / Loose Flange

General Information



Constructions with Sealing Sheeting

For constructions with sealing sheeting seals or wall sleeves with fixed / loose flanges are required in accordance with DIN 18195 T9. A difference is made between pressing water and non pressing water.

PSI Products offers, depending on the application, the appropriate solution: Seal with fixed / loose flange, wall sleeve with fixed / loose flange or on wall-face sleeve with fixed / loose flange. As standard quality, these products are delivered in galvanised steel, at the request of the customer they can be supplied in V2A/S304 or V4A/S316 stainless steel.

For Subsequent Mounting for Constructions without Sealing Sheeting

Wall penetrations with an excentric position, wrongly dimensioned core drills/wall sleeves or when the pipes or the building have subsided are always a problem for seals. For constructions without sealing sheeting, PSI Products has on wall-face sleeve in its delivery programme. They can of course also be manufactured in split/open version for subsequent mounting. As standard quality, these products are delivered in galvanised steel, at the request of the customer they can be supplied in V2A or V4A stainless steel.

Wall sleeve with fixed / loose flange



On wall-face sleeve



Seal with fixed / loose flange



Example of an individual solution for a wall sleeve with fixed / loose flange based on a drawing:

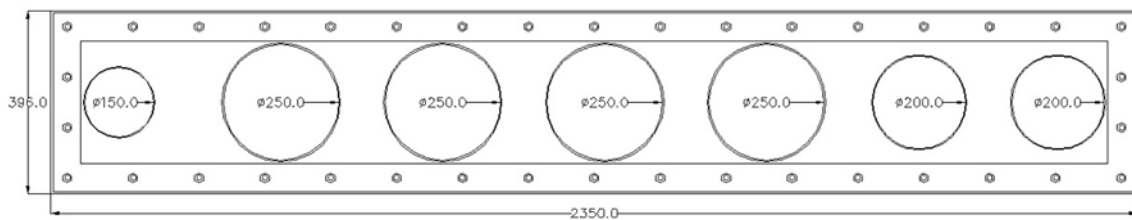

PSI Kompakt Seals and Wall Sleeves with Fixed / Loose Flange

Sectional View



sealing with fixed/loose flange according to DIN 18195 T 9
 steel parts galvanized, alternatively stainless steel

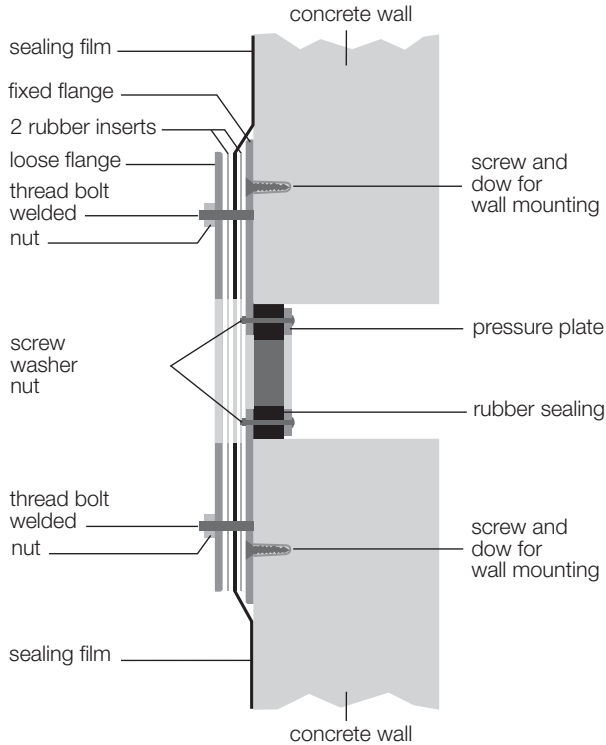

wall sleeve with fixed/loose flange according to DIN 18195 T 9
 steel parts galvanized, alternatively stainless steel

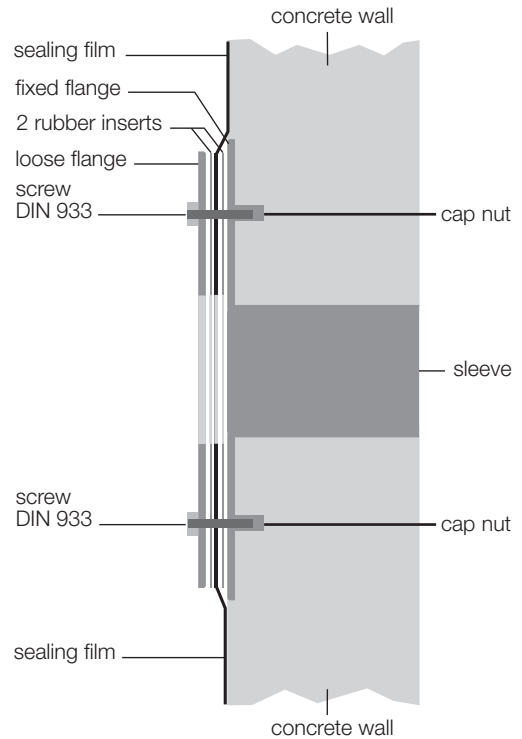

on wall-face sleeve with fix / loose flange according to DIN 18195 T 9, galvanized, alternatively stainless steel

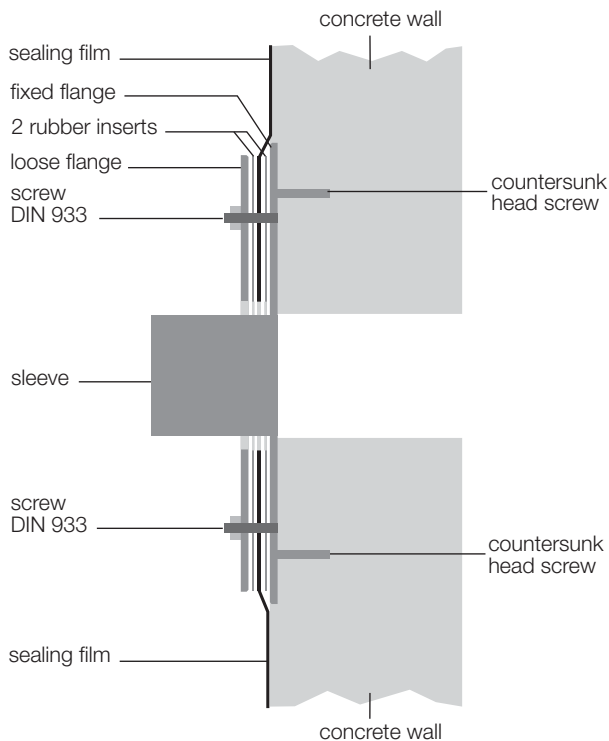

on wall-face sleeve in closed and split version, galvanized, alternatively stainless steel

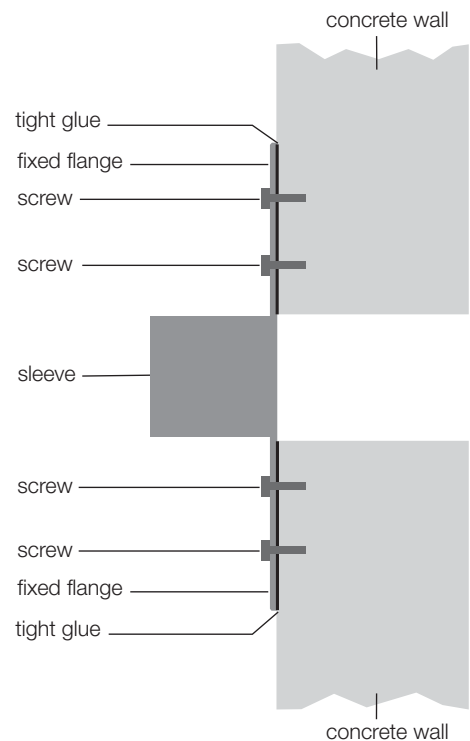

PSI Kompakt Seals and Wall Sleeves with Fixed / Loose Flange

Technical Data



Wall sleeves with fixed/loose flange complying with DIN 18195, Part 9 for constructions with sealing strips. Rubber inlays between flanges can be ordered additionally if necessary.

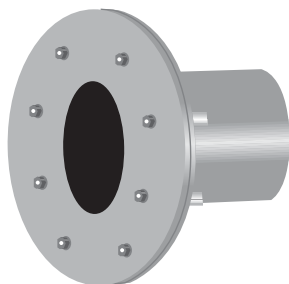

Wall sleeves with fixed/loose flange for non-pressing water, galvanized version

O.D. pipe	I.D. sleeve	O.D. fixed flange	length of wall sleeve
20-40	80	224	200
15-65	100	244	
55-78	125	269	
46-110	150	294	
88-160	200	344	
135-210	250	396	
178-226	300	446	
224-282	350	496	
270-330	400	548	
300-400	500	648	
400-500	600	748	
500-600	700	848	
600-700	800	948	
700-800	900	1050	
800-900	1000	1150	

Wall sleeves with fixed/loose flange for pressing water, galvanized version

O.D. pipe	I.D. sleeve	O.D. fixed flange	length of wall sleeve
20-40	80	404	200
15-65	100	424	
55-78	125	449	
46-110	150	474	
88-160	200	524	
135-210	250	576	
178-226	300	626	
224-282	350	676	
270-330	400	728	
300-400	500	828	
400-500	600	928	
500-600	700	1028	
600-700	800	1128	
700-800	900	1230	
800-900	1000	1330	

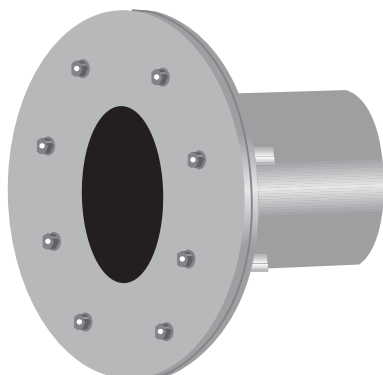

PSI inlays are elastomeric gaskets which are inserted between fixed and loose flanges.

When the sealing flashing is made of very thin or very hard material, the sealing of the steel undercoat is not sufficient. Therefore these sealing flashing require elastomer gaskets.

For the following sealing films, inlays are intended according to ECB, PIB, PVC-P, EPDM and EVA standards. We recommend inserting inlays also for films made of PE, PE-H and PVC.

PSI Kompakt Seals and Wall Sleeves with Fixed / Loose Flange

Technical Data



On wall-face sleeve with fixed / loose flange according to DIN 18195 T9 for buildings with sealing strips. Rubber inlays between flanges can be ordered additionally if necessary.

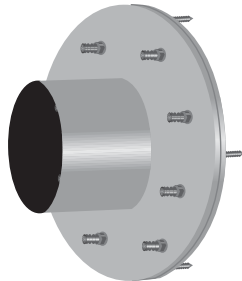

On wall-face sleeve with fixed/loose flange for non-pressing water, galvanized

O.D. pipe	I.D. sleeve	O.D. fixed flange	length of wall sleeve
20-40	80	224	100
15-65	100	244	
55-78	125	269	
46-110	150	294	
88-160	200	344	
135-210	250	396	
178-226	300	446	
224-282	350	496	
270-330	400	548	
300-400	500	648	
400-500	600	748	
500-600	700	848	
600-700	800	948	
700-800	900	1050	
800-900	1000	1150	

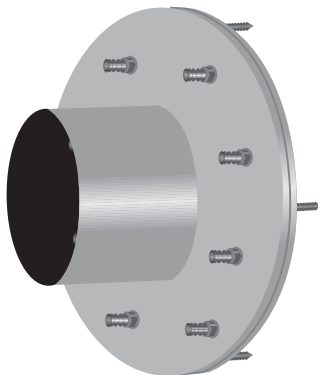

On wall-face sleeve with fixed/loose flange for pressing water, galvanized

O.D. pipe	I.D. sleeve	O.D. fixed flange	length of wall sleeve
20-40	80	404	100
15-65	100	424	
55-78	125	449	
46-110	150	474	
88-160	200	524	
135-210	250	576	
178-226	300	626	
224-282	350	676	
270-330	400	728	
300-400	500	828	
400-500	600	928	
500-600	700	1028	
600-700	800	1128	
700-800	900	1230	
800-900	1000	1330	

Further sizes and types in stainless steel on request.

Seals with fixed/loose flange complying with DIN 18195, Part 9 for constructions with sealing strips. Rubber inlays between flanges can be ordered additionally if necessary.



Seals with fixed/loose flange against non-pressing water, galvanized version

O.D. pipe	Core drill / I.D. wall sleeve	O.D. fixed flange
20-40	80	224
15-65	100	244
55-78	125	269
46-110	150	294
88-144	200	344
135-187	250	396
178-226	300	446
224-282	350	496
270-330	400	546
300-400	500	648
400-500	600	748
500-600	700	848
600-700	800	948
700-800	900	1050
800-900	1000	1150

PSI inlays are elastomer gaskets which are inserted between fixed and loose flanges. When the sealing film is made of very thin or very hard material, the sealing of the steel undercoat is not sufficient. Therefore these sealing films require elastomer gaskets. For the following sealing films, inlays are intended according to ECB, PIB, PVC-P, EPDM and EVA standards. We recommend inserting inlays also for films made of PE, PE-H and PVC.

PSI Kompakt Seals and Wall Sleeves with Fixed / Loose Flange

Technical Data



Seals with fixed/loose flange

complying with DIN 18195, Part 9 for constructions with sealing strips. Rubber inlays between flanges can be ordered additionally, if necessary.



PSI inlays are elastomer gaskets which are inserted between fixed and loose flanges. When the sealing film is made of very thin or very hard material, the sealing of the steel undercoat is not sufficient. Therefore these sealing films require elastomer gaskets. For the following sealing films, inlays are intended according to ECB, PIB, PVC-P, EPDM and EVA standards. We recommend inserting inlays also for films made of PE, PE-H and PVC.

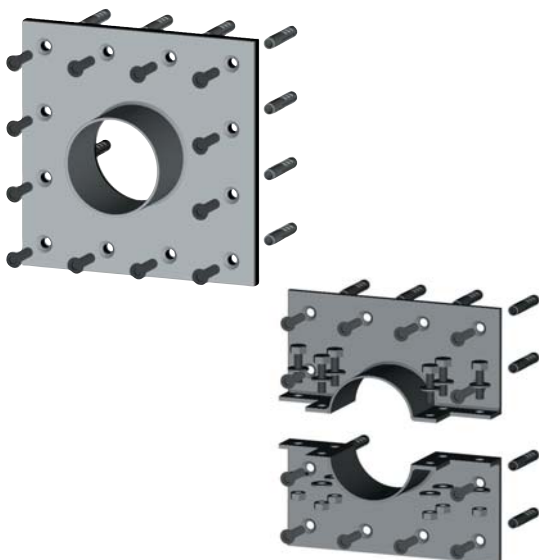

Seals with fixed/loose flange against pressing water, galvanized version

O.D. pipe	O.D. sealing	O.D. fixed flange
20-40	80	404
15-65	100	424
55-78	125	449
46-110	150	474
88-144	200	524
135-187	250	576
178-226	300	626
224-282	350	676
270-330	400	728
300-400	500	828
400-500	600	928
500-600	700	1028
600-700	800	1128
700-800	900	1230
800-900	1000	1330

On wall-face sleeve closed and split/open versions - galvanized. For installation in front of a wall or beneath a ceiling, including sealing compound for the wall and fastening materials.

O.D. Pipe	I.D. sleeve	fixed flange edge length	length of sealing collar
20-40	80	280	60 mm
15-65	100	300	
55-78	125	325	
46-110	150	350	
88-160	200	400	
135-210	250	450	
178-226	300	500	
224-282	350	550	
270-330	400	600	
300-400	500	700	
400-500	600	800	100 mm
500-600	700	900	
600-700	800	1000	
700-800	900	1100	
800-900	1000	1200	

Further sizes and types in stainless steel on request.

PSI Seal with Fixed / Loose Flange for Non-Pressing or Pressing Water Installation Instruction



General

- Please compare the data on the sealing insert with the carrier pipe and casing/core drilling diameter.
- PSI pipe penetrations are neither an anchor point nor a pipe support.

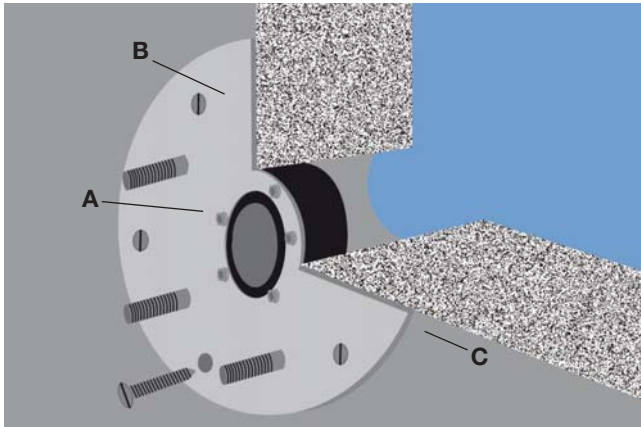

Fastening of the sealing insert inside the wall

- Insert the component with the sealing insert in the casing/core drilling and fasten it slightly by tightening the screws (A)
- Mark the drill holes, untighten the screws and remove the component. Bore the holes, insert the dowels and fasten the component to the wall.
- Level the junction of the fixed flange and the wall with mortar (C)

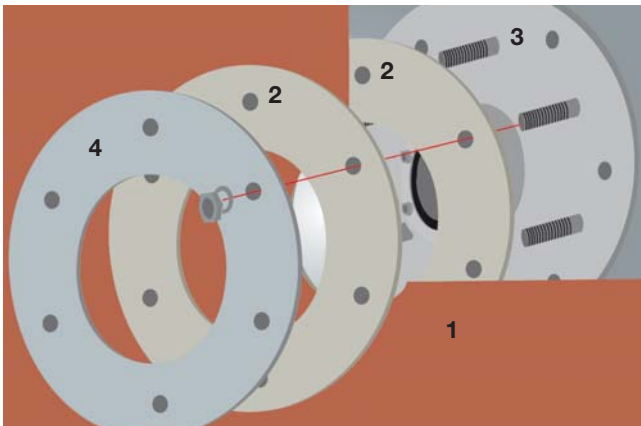

Laying of the sealing sheeting, assembly of the loose flange for loose and bonded sealing sheetings

- Cut the sealing sheeting (1) (and any necessary inserts* (2) for loosely laid sheetings in accordance with the sheeting manufacturer's specification), (the loose flange can be used as a template)
- Place the inserts and the sealing sheeting on the fixed flange construction (3).
- Fit the loose flange (4) (the bevelled side facing the sealing sheeting), the washers and the nuts.

* Please order inserts separately

PSI Seal with Fixed / Loose Flange for Non-Pressing or Pressing Water Installation Instruction

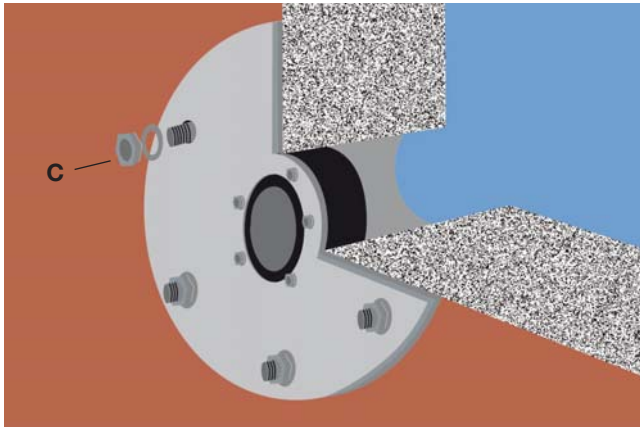

Bracing of the sealing sheeting

Tighten the nuts (C) crosswise several times to brace the sealing sheeting. **Please bear in mind: torques according to sheeting manufacturer's specification or to DIN 18195 (see table).**

Torques for tightening Kompakt seals

Nuts	Max. torque	Max. torque for thin-walled plastic pipes
M 6	5 Nm	5 Nm
M 8	10 Nm	8 Nm
M 10	15 Nm	10 Nm
M 12	20 Nm	15 Nm

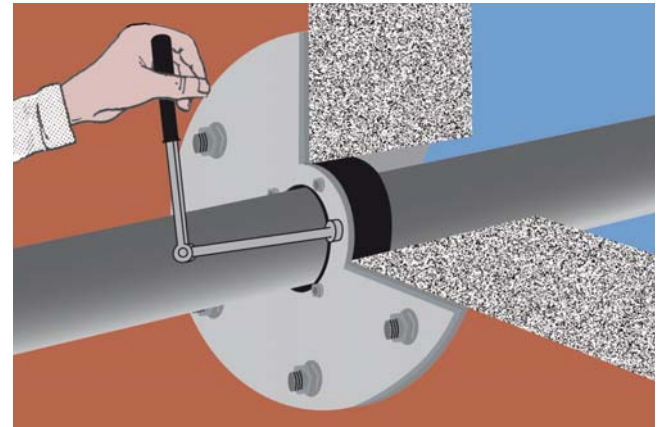

Mounting of the sealing insert

- Lay the pipe centred through the sealing insert.
- Tighten the nuts clockwise a few turns (see table), however, not exceeding the torque listed opposite.
- Important for several rows of bolts: first tighten the nuts of the inner bolt row.

Please note: We recommend reducing the respective maximum torques in case of particularly thin-walled plastic pipes such as flexible casing and corrugated pipes (see table)

Warning:

Please observe the sheeting manufacture's standard torque values or DIN 18195 when tightening the nuts

Type of sealing coat	Torque for M12 (Nm)	Torque for M20 (Nm)
Bare bitumen sheetings according to DIN 52129-R 500 N	12*	50*
PIB bonded with bitumen	12*	50*
Bitumen sheetings and polymer bitumen sheetings according to DIN 18195-2, table 4 with glass fabric lining material	15*	55*
Bitumen sheetings and polymer bitumen sheetings according to DIN 18195-08, table 4 with polyester fleece or copper plate lining material	20*	80*
500 N + 1 Cu	20*	1. tightening 100* 2. and 3. tightening 80*
ECB sheetings, PVC-P sheetings, elastomer sheetings and EVA sheetings bonded with bitumen according to DIN 18195-2:2000-08, tables 5 and 7		20* 80*
R 500 N + 2x Cu	30*	1. tightening 120* 2. tightening 100* 3. tightening 80*
Plastic seals loosely laid according to DIN 18195-2:2000-08, tables 5 and 7	30*	100*

* torque in accordance with DIN 18195-9

PSI Wall Sleeve with Fixed / Loose Flange for Non-Pressing or Pressing Water

Installation Instruction

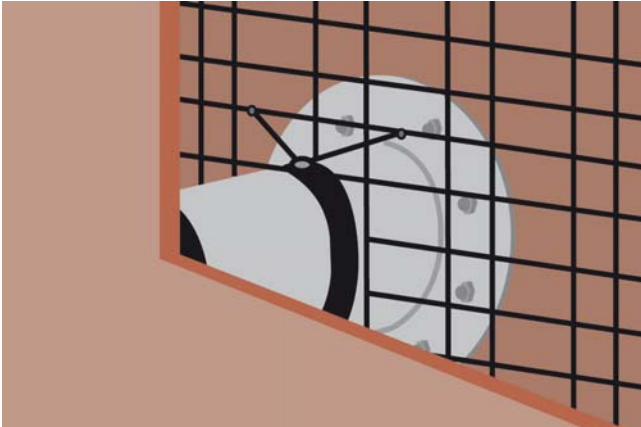

Fasten pipe clip to steel casing by means of welded joints (pipe clip on site).

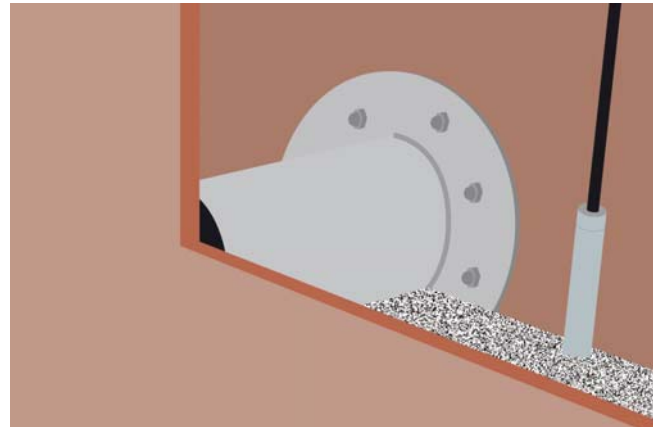

Concrete must be well compacted near casing pipe.

Fitting Instructions for Sealing Sheatings

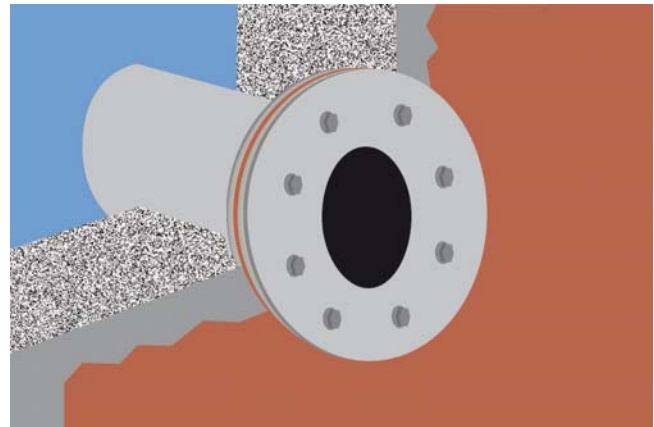
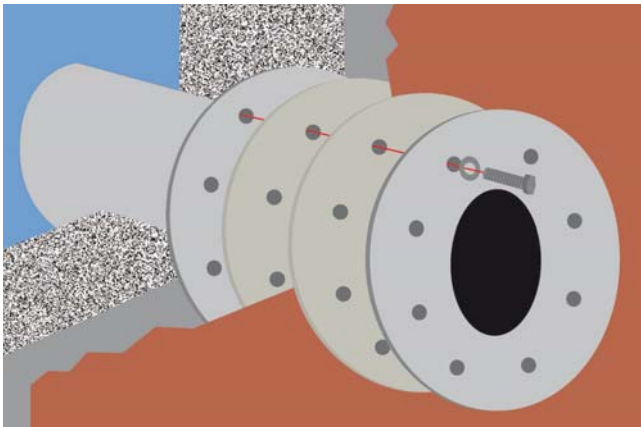

For loose and bonded sealing sheetings

Lay sealing sheeting / mount loose flange

- Cut the sealing sheeting and install, if necessary, inserts made of the sealing sheeting material (in accordance with manufacturer's specification) on both sides of the sealing sheeting(s).
Alternative: ready-made inserts*
- Place the inserts and the sealing sheeting on the fixed flange construction.
- Fit the loose flange.
Warning: Mount the bevelled side facing the sealing sheeting.
- Brace the sealing sheeting
Tighten the nuts crosswise several times to brace the sealing sheeting. **Please bear in mind: torques according to sheeting manufacturer's specification or to DIN 18195 (see table).**

* Please order inserts separately

PSI Wall Sleeve with Fixed / Loose Flange for Non-Pressing or Pressing Water



Installation Instruction

Warning:

Please observe the sheeting manufacture's standard torque values or DIN 18195 when tightening the nuts

Type of sealing coat	Torque for M12 (Nm)	Torque for M20 (Nm)
For KMB (polymer modified high build coatings)	30	100
Bare bitumen sheetings according to DIN 52129-R 500 N	12*	50*
PIB bonded with bitument	12*	50*
Bitumen sheetings and polymer bitumen sheetings according to DIN 18195-2:2000-08, table 4 with glass fabric lining material	15*	65*
Bitumen sheetings and polymer bitumen sheetings according to DIN 18195-08, table 4 with polyester fleece or copper plate lining material	20*	80*
500 N + 1 Cu	20*	1. tightening 100* 2. and 3. tightening 80*
ECB sheetings, PVC-P sheetings, elastomer sheetings and EVA sheetings bonded with bitumen according to DIN 18195-2:2000-08, tables 5 and 7	20*	80*
R 500 N + 2x Cu	30*	1. tightening 120* 2. tightening 100* 3. tightening 80*
Plastic seals loosely laid according to DIN 18195-2:2000-08, tables 5 and 7	30*	100*

* torque in accordance with DIN 18195-9

PSI On Wall-Face Sleeve with Fixed / Loose Flange for Non-Pressing or Pressing Water



Installation Instruction

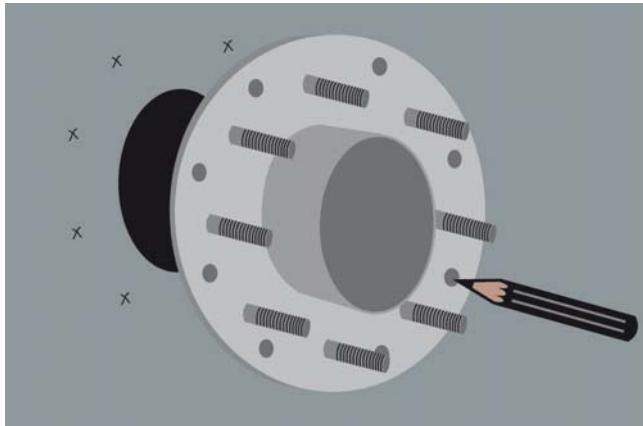

Hold casing pipe against the wall and mark dowel holes.

Please note: Position the casing pipe centrally to the pipe if the pipe has already been laid!

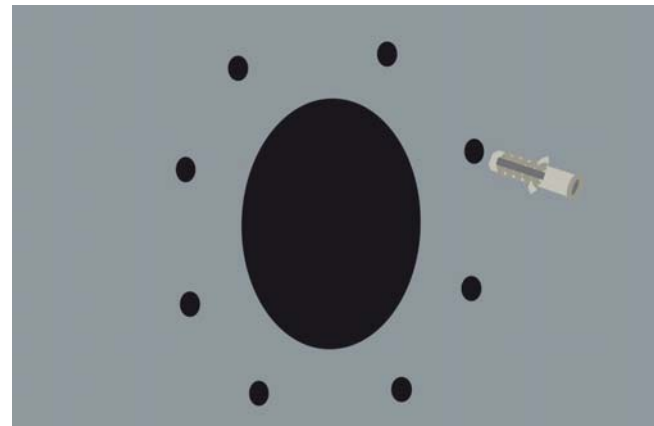

Bore the dowel holes and place the dowels.

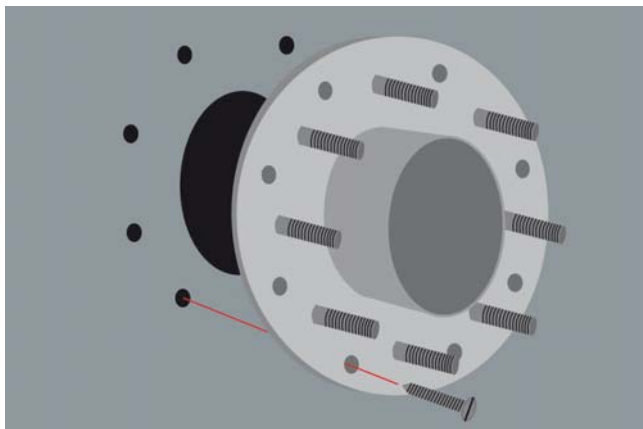

Fasten the casing pipe to the wall by tightening the screws.

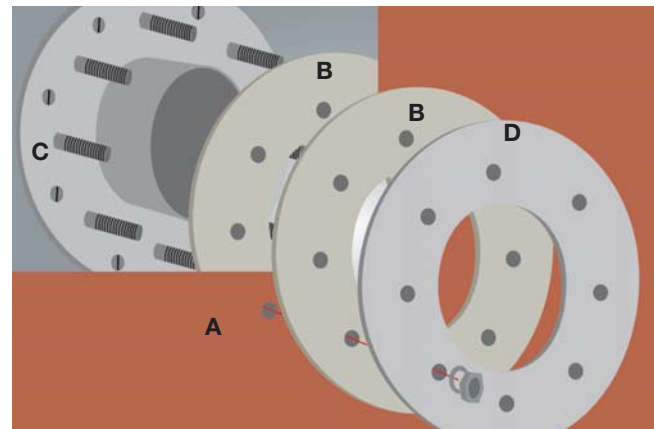

For loose and bonded sealing sheetings

Lay sealing sheeting / mount loose flange

- Cut the sealing sheeting and install, if necessary, inserts made of the sealing sheeting material (in accordance with manufacturer's specification) on both sides of the sealing sheeting(s).
Alternative: ready-made inserts*
- Place the inserts and the sealing sheeting on the fixed flange construction.
- Fit the loose flange.
Warning: Mount the bevelled side facing the sealing sheeting.

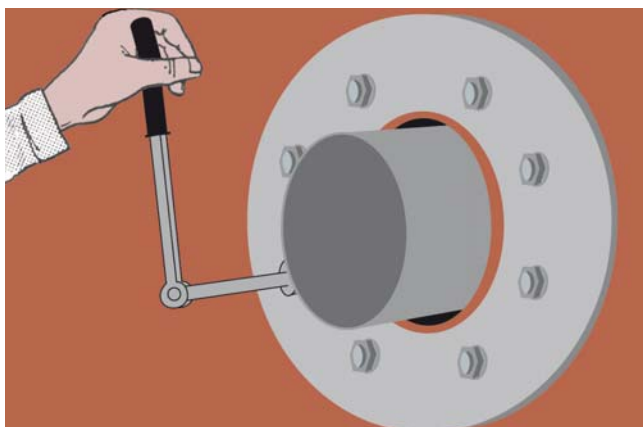

Brace the sealing sheeting – Tighten the nuts crosswise several times to brace the sealing sheeting.

Please bear in mind:

torques according to sheeting manufacturer's specification or to DIN 18195 (see table).

* Please order inserts separately

PSI On Wall-Face Sleeve with Fixed / Loose Flange for Non-Pressing or Pressing Water



Installation Instruction

Warning:

Please observe the sheeting manufacture's standard torque values or DIN 18195 when tightening the nuts

Type of sealing sheeting and/or high build coating	Torque for M12 (Nm)	Torque for M20 (Nm)
Bare bitumen sheetings according to DIN 52129-R 500 N	12*	50*
PIB bonded with bitumen	12*	50*
Bitumen sheetings and polymer bitumen sheetings according to DIN 18195-2, table 4 with glass fabric lining material	15*	55*
Bitumen sheetings and polymer bitumen sheetings according to DIN 18195-08, table 4 with polyester fleece or copper plate lining material	20*	80*
500 N + 1 Cu	20*	1. tightening 100* 2. and 3. tightening 80*
ECB sheetings, PVC-P sheetings, elastomer sheetings and EVA sheetings bonded with bitumen according to DIN 18195-2:2000-08, tables 5 and 7		20* 80*
R 500 N + 2x Cu	30*	1. tightening 120* 2. tightening 100* 3. tightening 80*
Plastic seals loosely laid according to DIN 18195-2:2000-08, tables 5 and 7	30*	100*

* torque in accordance with DIN 18195-9

PSI On Wall-Face Sleeve Closed Version

Installation Instruction



Closed version:

1. Press sleeve against the wall, adjust the sleeve on the borehole resp. wall penetration and mark drilling holes.

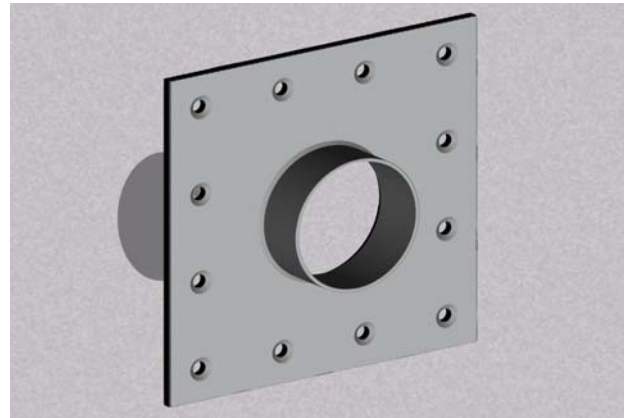

2. Remove sleeve from the wall and bore holes.

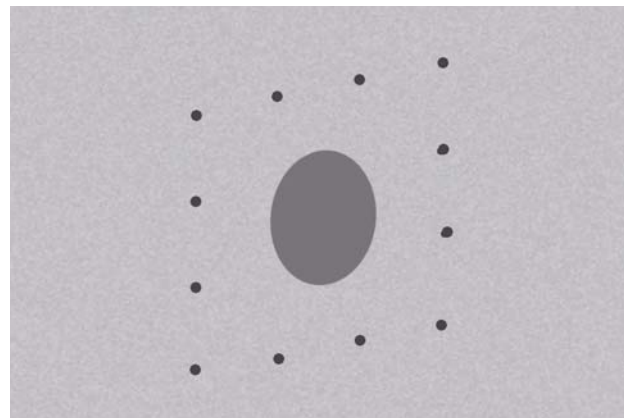

3. Apply included sealing compound on the backside of sleeve (in thick stripes \varnothing 6mm – 10mm), one stripe between the outside edge of flange and screwhole. An other one between welded sleeve and screwhole. Put last stripe around the screwhole.

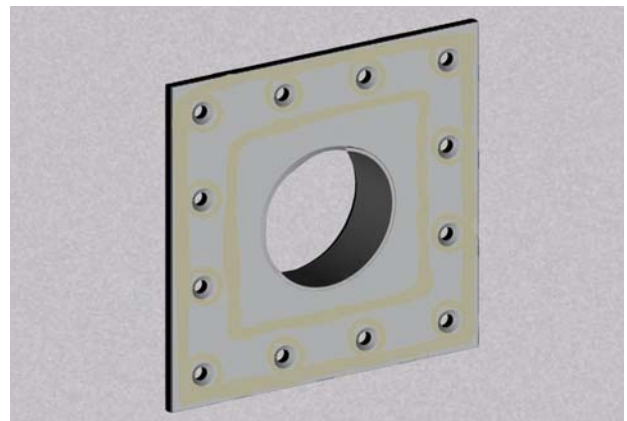

4. Screw the sleeve on the wall (bolts and anchor for concrete wall are included). Spread discharged sealing compound.

5. After that you can assemble the wall penetration seal (see application manual of wall penetration seal).

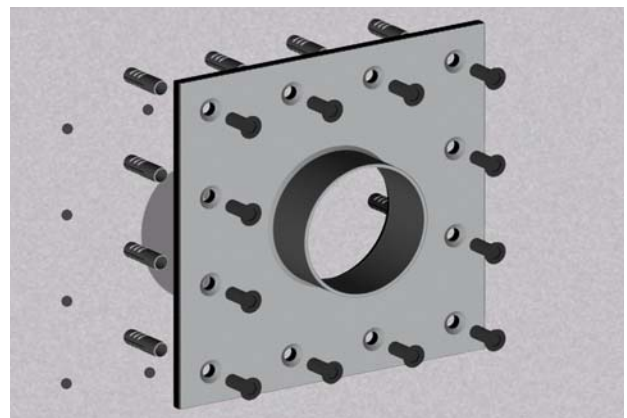

PSI On Wall-Face Sleeve Split Version Installation Instruction



Split version:

1. Press sleeve against the wall, centre assembled sleeve with support of seal on the pipe and mark drilling holes.

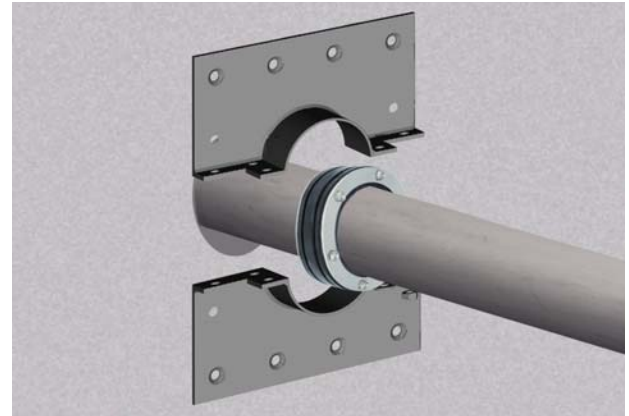

2. Remove sleeve and seal from the wall and bore holes.

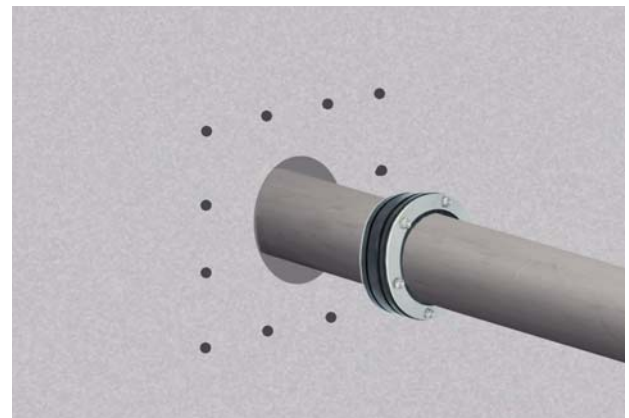

3. Apply included sealing compound on the backside of sleeve (in thick stripes \varnothing 6 - 10mm), one stripe between the outside edge of flange and screwhole. An other one between welded sleeve and screwhole. Put last stripe around the screwhole.

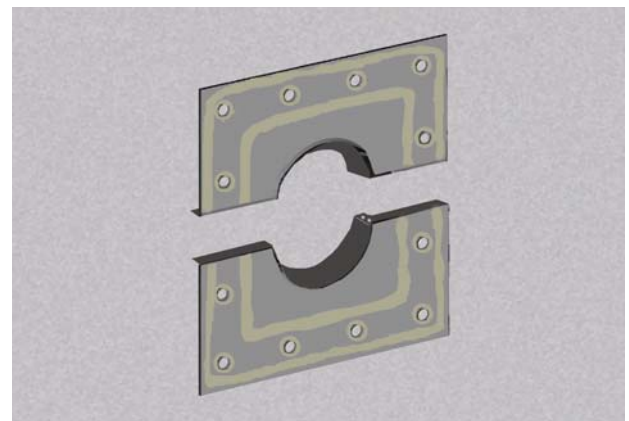

4. First put seal and then sleeve around the pipe. Now put rubber gasket between the two halves of sleeve and assemble all.

At last fix assembled sleeve on the wall (bolts and anchor for concrete wall and rubber gaskets of the two halves of sleeve are included). Spread discharged sealing compound.

5. Tighten screws of the sealing (see application manual of sealing).

